

APPLICATION DATA – Model: FLX | Fuel Series: 700 | Design Pressure: 150 psi Steam | Operating Pressure: 125 psi | System Voltage: 460/3/60 | NOx Emissions Level: 30ppm | Feedwater Temperature: 212°F | Elevation: 700 ft ASL

Input Capacity [10 MBtu/hr]:	DIM	150	200	250	300	350	400	450	500	550	600	700	800	900	1000	1100	1200	
Clearances [in.]																		
Boiler:	MAGENTA	18	18	18	18	18	18	18	18	18	18	18	18	18	18	18	18	18
Electrical Panel (460V):	GREEN*	42	42	42	42	42	42	42	42	42	42	42	42	42	42	42	42	42
Tube Removal:	ORANGE	28	28	28	32	32	34	34	34	34	34	40	40	40	40	40	40	40
Service Area (Rear):	ORANGE	24	24	24	24	24	24	24	24	24	24	24	24	24	24	24	24	24
Service Area (Front):	ORANGE	48	48	48	48	48	60	60	60	60	60	60	60	60	60	60	60	60
Front Door Swing:	BLUE																	

[GREEN*] NOTE: Electrical panel location determined by application.

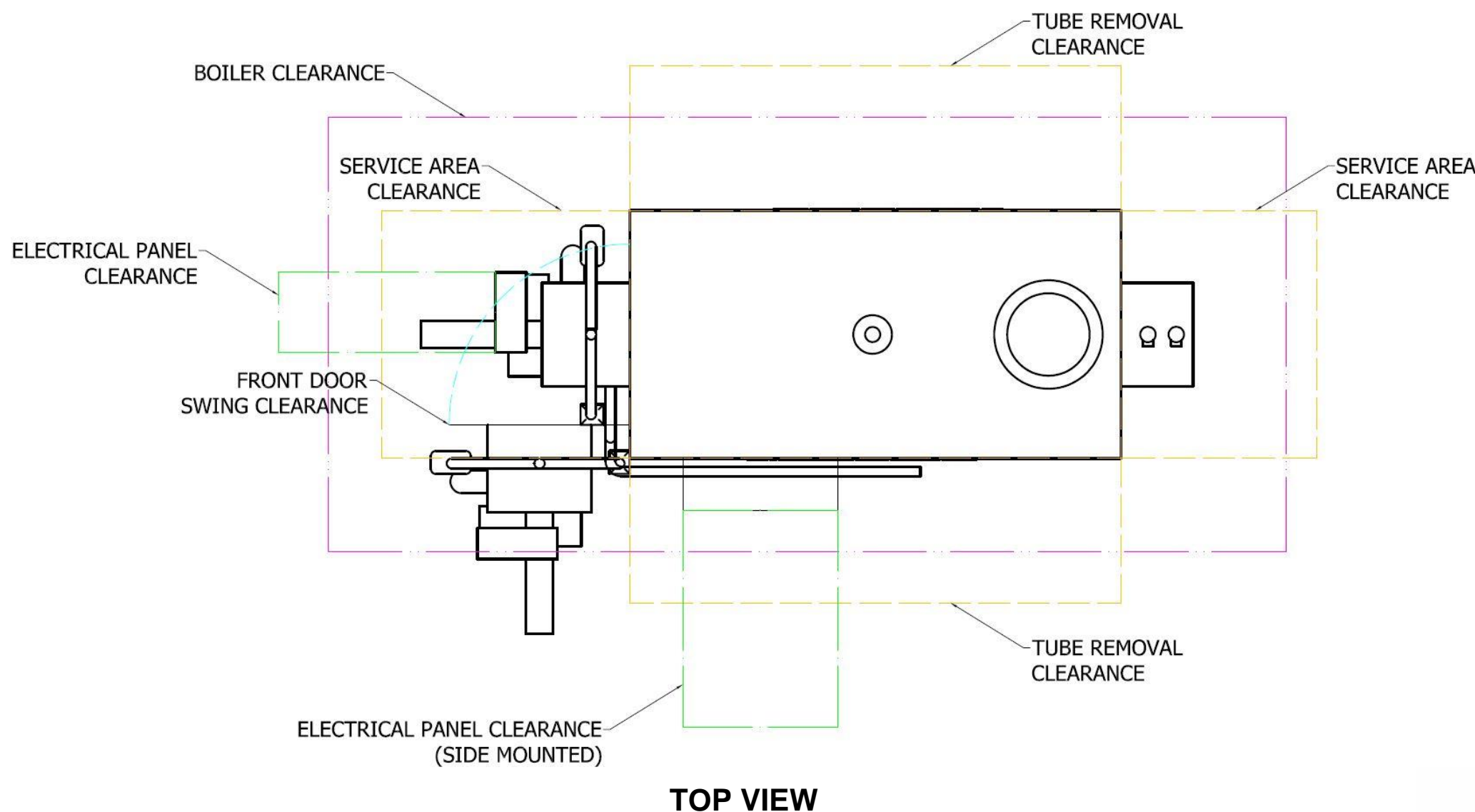
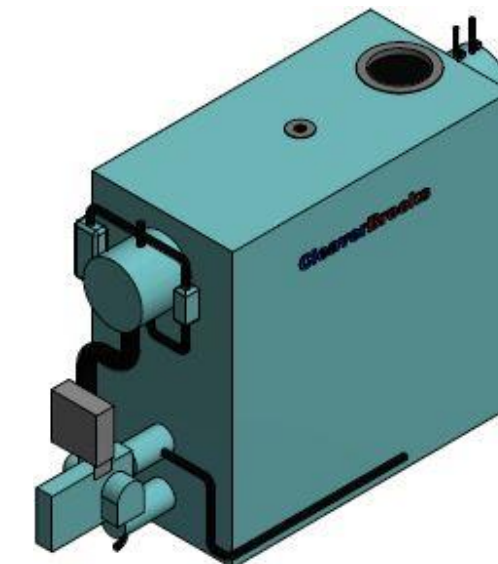

NOTE: All dimensions are approximate. Product data may vary based on application. Contact your local Cleaver-Brooks representative for additional information.